

■ ■ ■ ■ ■ ■ online
coplanar
sliding system

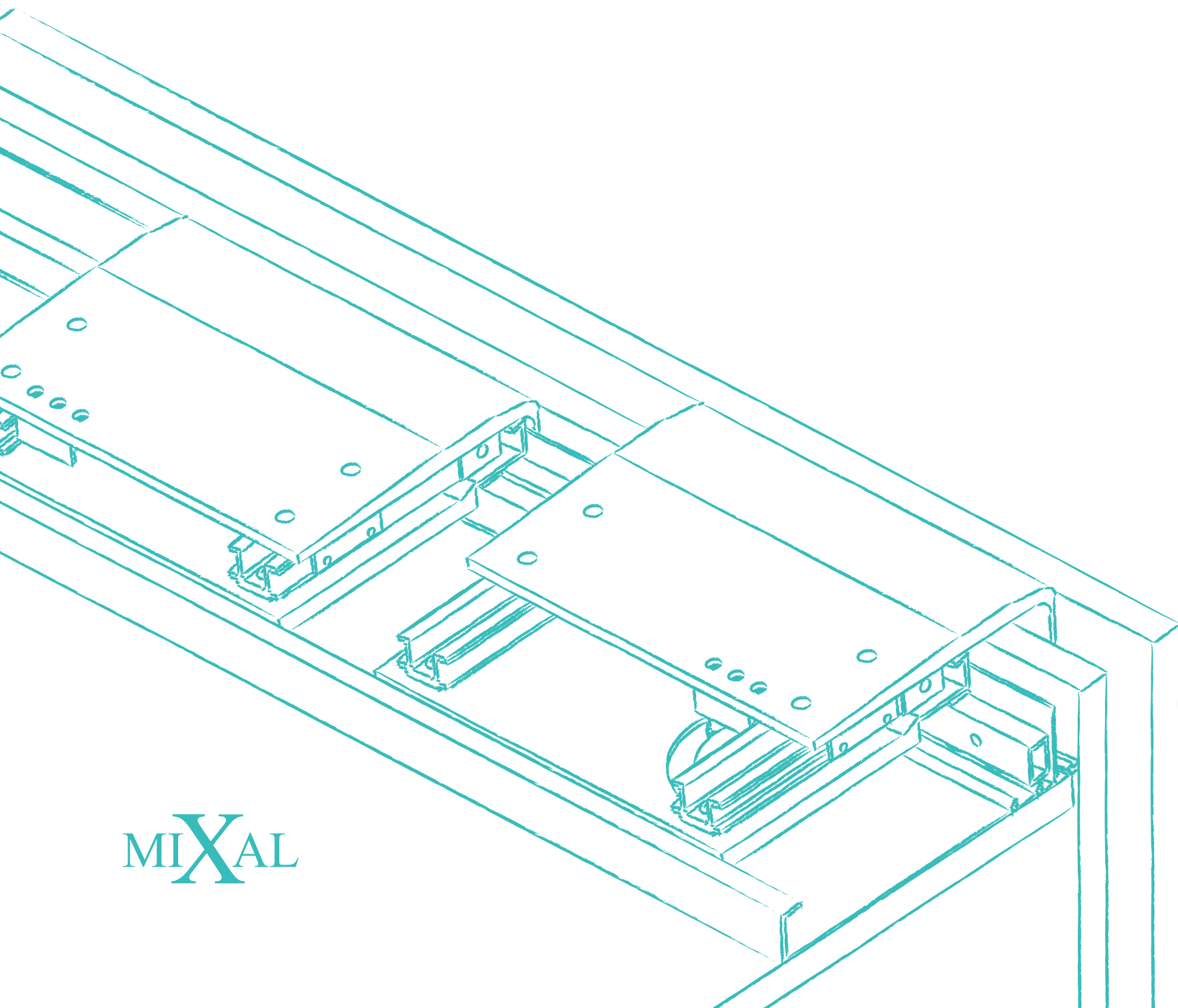

MIXAL

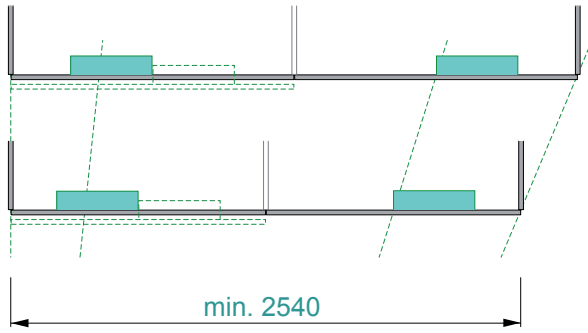

online2

SISTEMA 2 ANTE
2 doors system

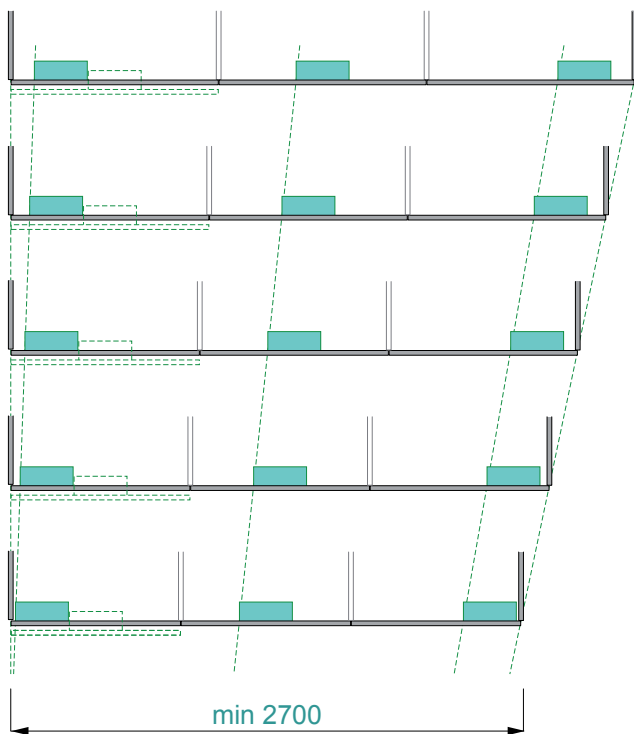
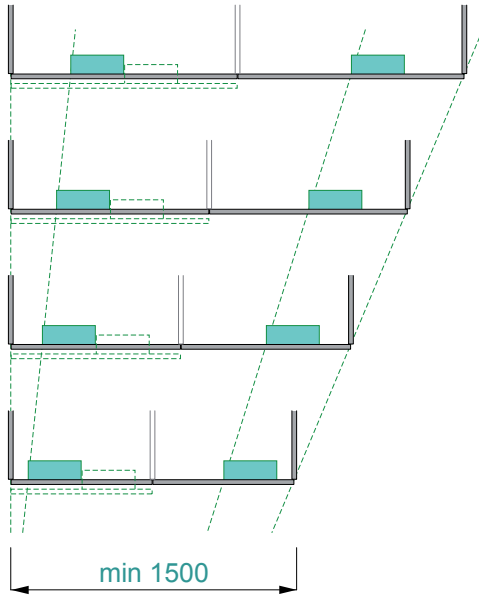

online3

SISTEMA 3 ANTE
3 doors system

Il kit carrello comprende / the truck kit includes:
 il meccanismo DX/SX/CX completo di curve e tutti gli accessori per il montaggio ed il funzionamento
 the right/left/central mechanism with curves and all the accessories for installation and operation

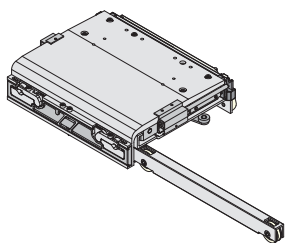

Carrello sinistro
 Left truck
max. 55kg

kit H33: [ANSXONLIH33LI](#)
 kit H17: [ANSXONLIH17LI](#)

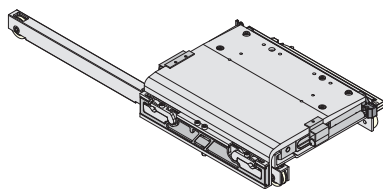

Carrello destro
 Right truck
max. 55kg

kit H33: [ANDXONLIH33LI](#)
 kit H17: [ANDXONLIH17LI](#)

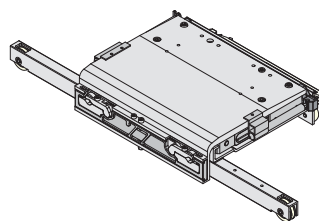

Carrello centrale
 Central truck
max. 55kg

apertura SX / left opening
 kit H33: [ANCXSXLIH33LI](#)
 kit H17: [ANCXSXLIH17LI](#)
 apertura DX / right opening
 kit H33: [ANCXDCLIH33LI](#)
 kit H17: [ANCXDCLIH17LI](#)

*Attenzione: specificare
 apertura sinistra o destra
 Attention: specify left or right
 opening*

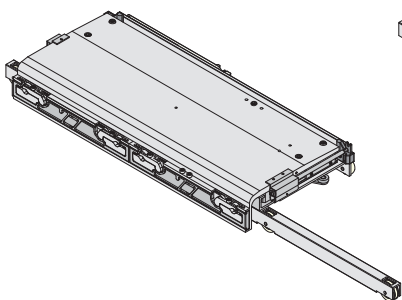

Carrello sinistro large
 Large left truck
max. 85kg

G online2 ≥ 1270 mm

kit H33: [ANSXONLIH33ST](#)
 kit H17: [ANSXONLIH17ST](#)

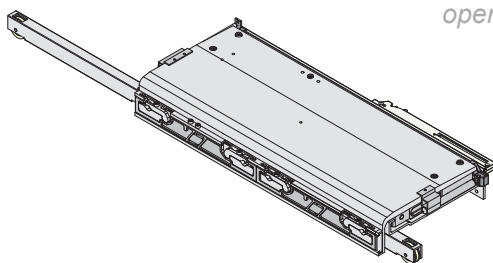

Carrello destro large
 Large right truck
max. 85kg

G online2 ≥ 1270 mm

kit H33: [ANDXONLIH33ST](#)
 kit H17: [ANDXONLIH17ST](#)

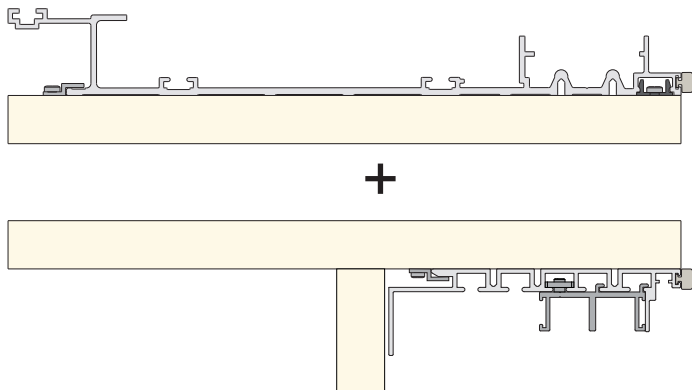

Binario superiore
 Top rail

Binario inferiore
 Bottom rail

code: [P1031482Axxxx](#)

*xxxx = lunghezza cliente
 xxxx = customer length*





MONTAGGIO PROFILO "Z"
"Z" profile mounting

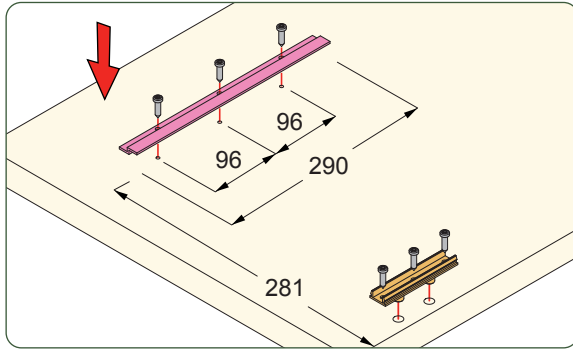

MONTAGGIO CLIP E30171
E30171 mounting

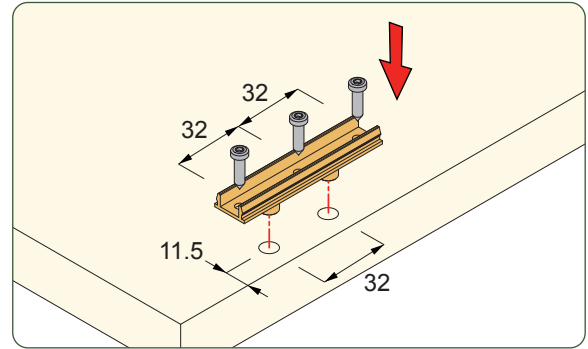

AGGANCIAMENTO BINARI
rail mounting

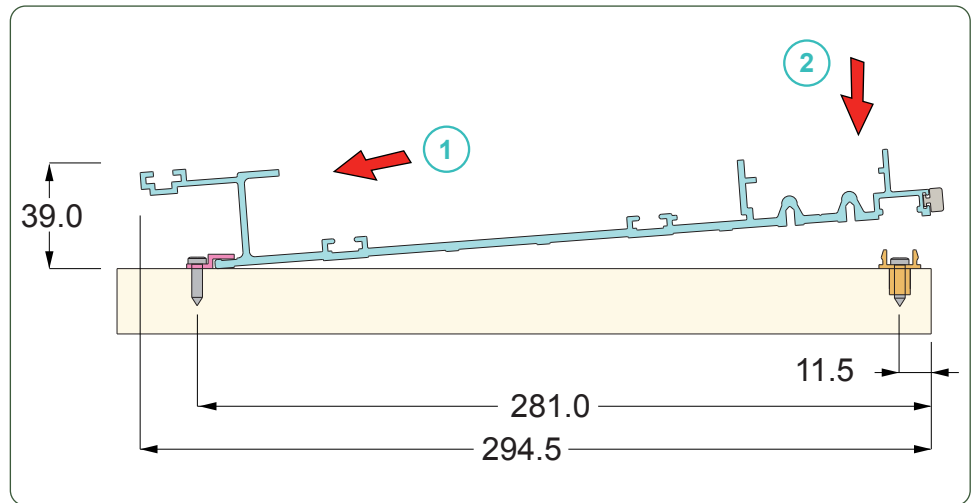

POSIZIONAMENTO CURVE SUPERIORI
upper curves mounting

E pp 6,7,8

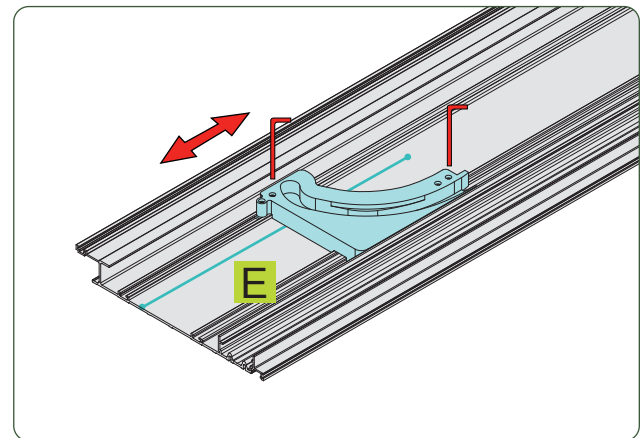

REGOLAZIONE ATTIVATORE FRENO AMMORTIZZATO
upper soft colosing system actuator

online2 **a** + **b**

online3 **a** + **b** + **c**

! Verso dell'attivatore
actuator direction

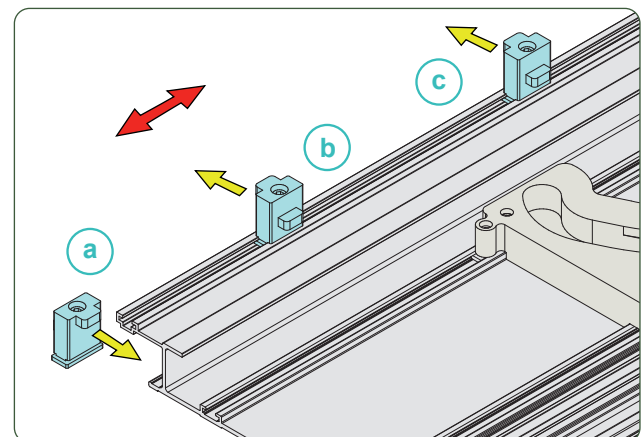

FORO PER BUSSOLA FILETTATA
hole bush threaded

spalle laterali / side panels

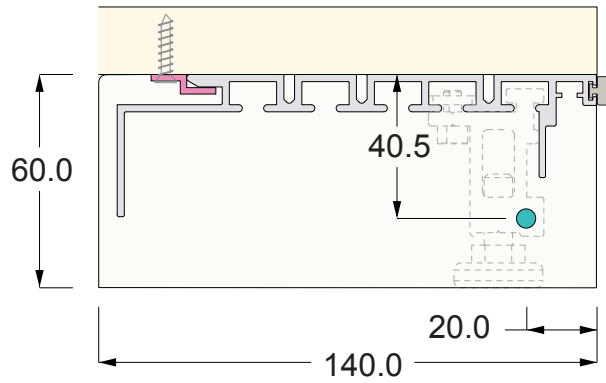
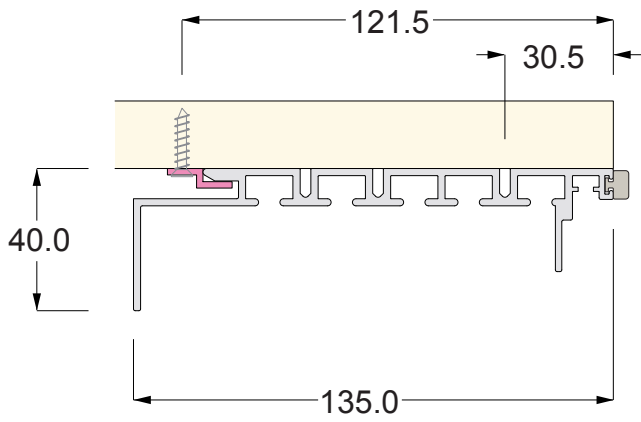

POSIZIONAMENTO BINARIO INTERMEDIO INFERIORE
lower middle rail mounting

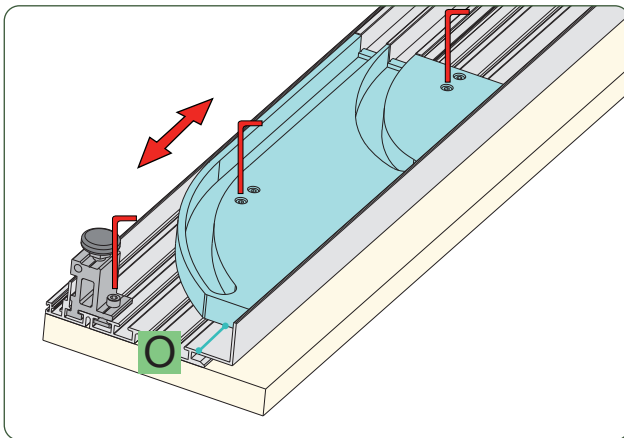
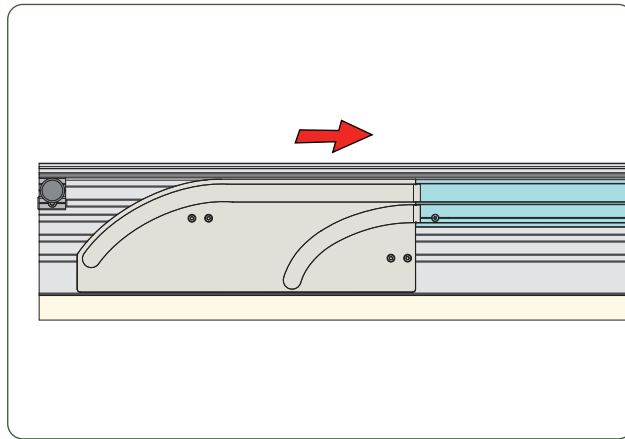
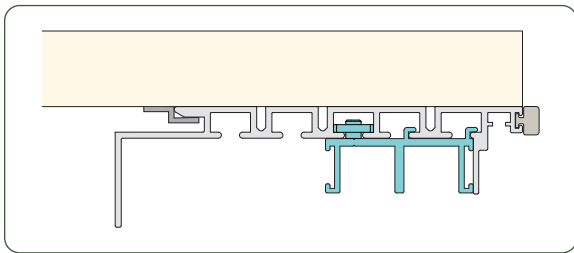

POSIZIONAMENTO CURVE INFERIORI
lower curves mounting

O pp 6,7,8

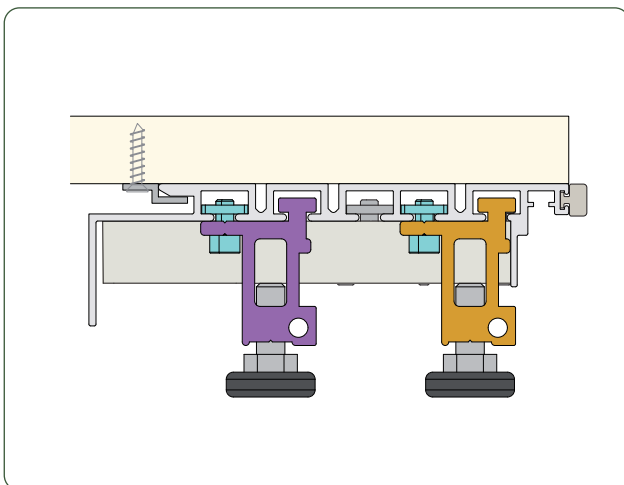
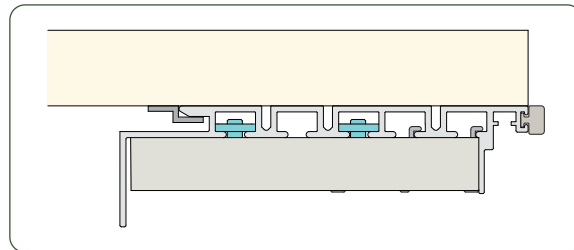

MONTAGGIO PIEDINI INFERIORI
lower feet mounting

fissare alle spalle laterali
fixed on side panels
posizionare in corrispondenza delle spalle centrali
place under central panels

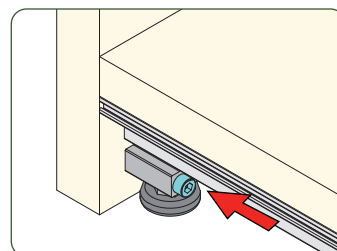

binario inf.



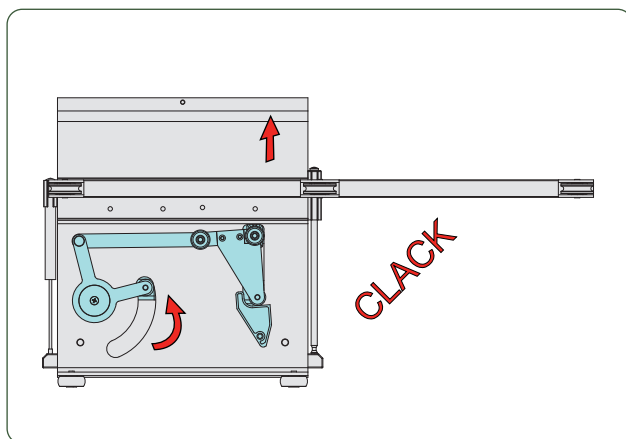

APERTURA CARRELLO
truck opening

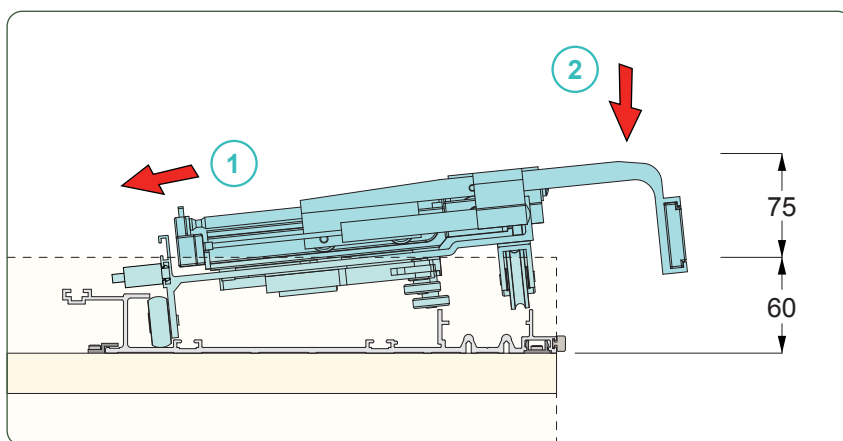

INSERIMENTO
CARRELLO
truck mounting

! *il carrello deve essere aperto*
the truck must be open

FISSAGGIO STAFFE ANTA **online2**
doors connecting plates mounting

! *Piastra superiore DX e SX*
Upper metal connecting plate right and left

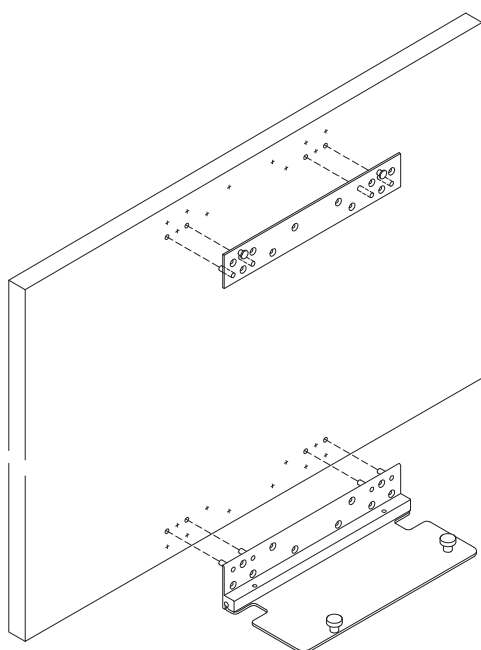

FISSAGGIO STAFFE ANTA **online3**
doors connecting plates mounting

! *Piastra superiore DX, SX e CX*
Upper metal connecting plate right, left and central

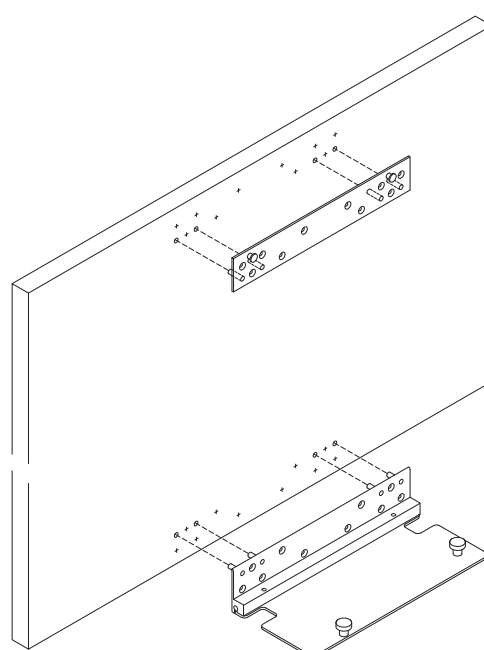

H17

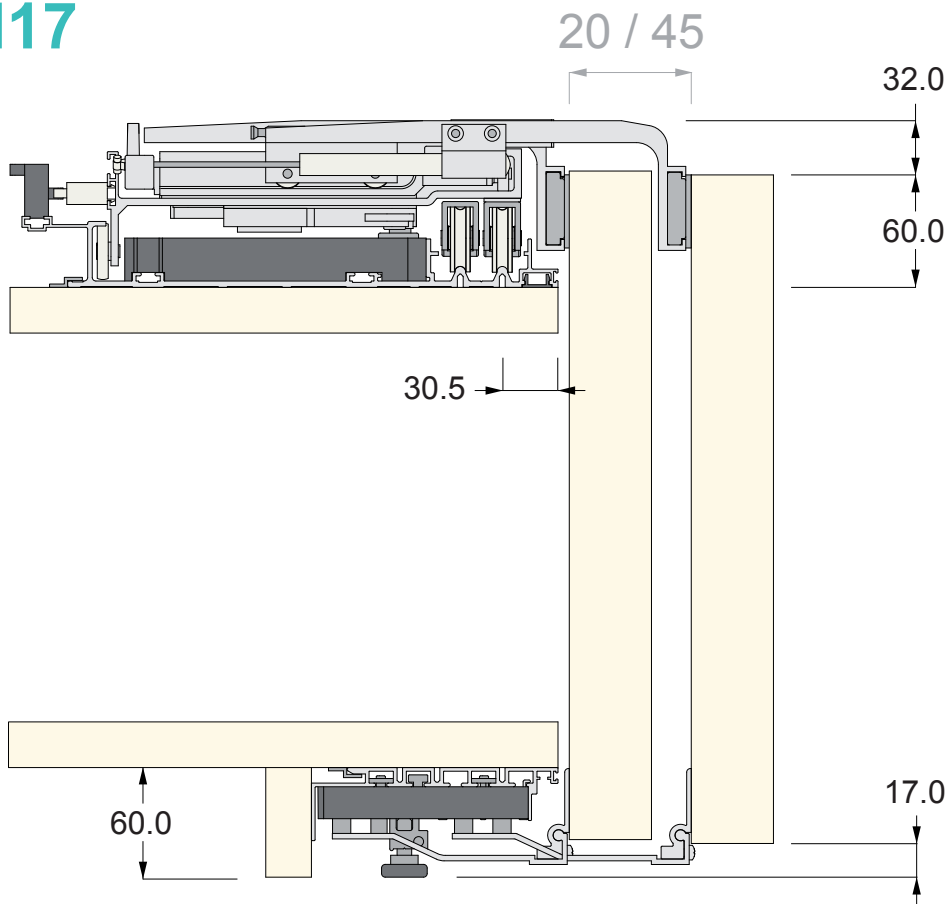

H33

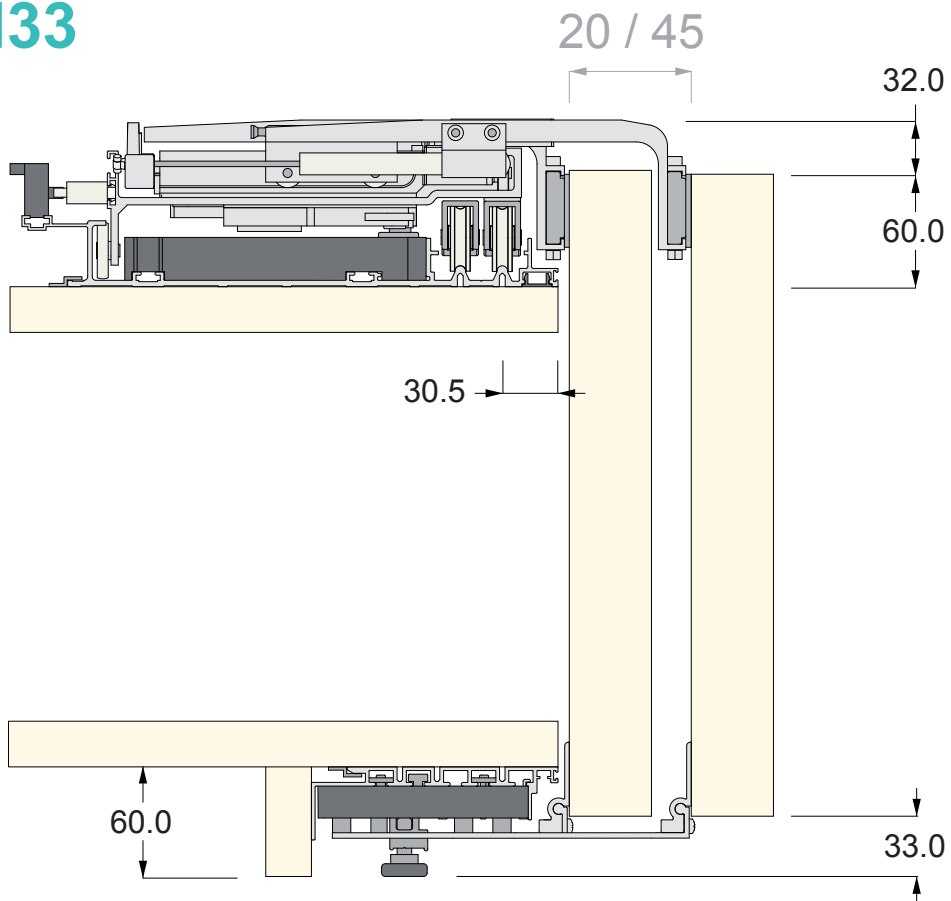

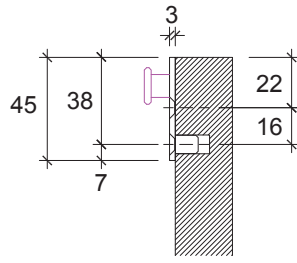

FISSAGGIO STAFFA SUPERIORE STANDARD

Upper metal connecting plate

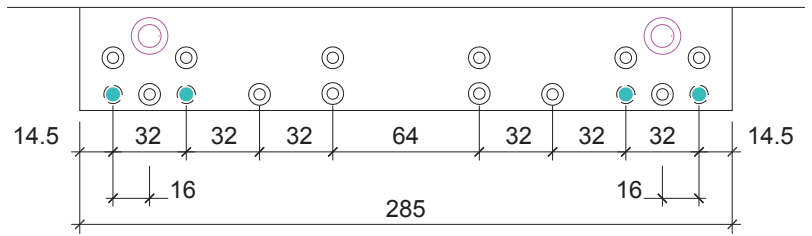

FISSAGGIO STAFFA SUPERIORE LARGE

Upper metal connecting plate

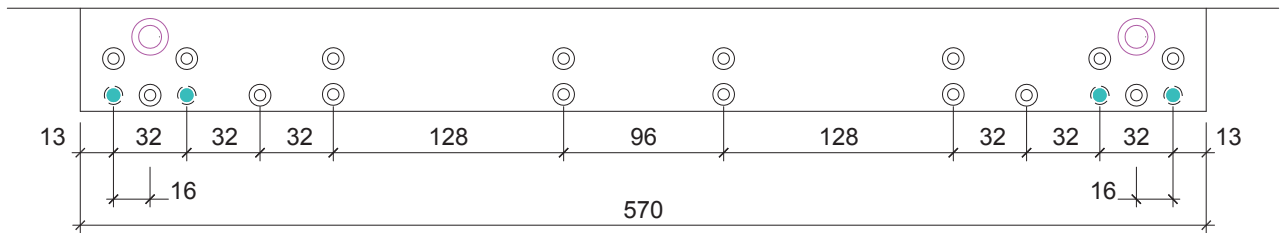

● spine di centraggio / dowel pin
fori ciechi / holes $\varnothing 8.2$ prof. / depth 15mm

⊙ viti di fissaggio / screws

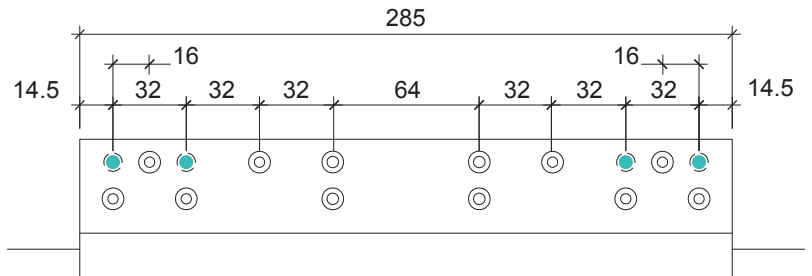
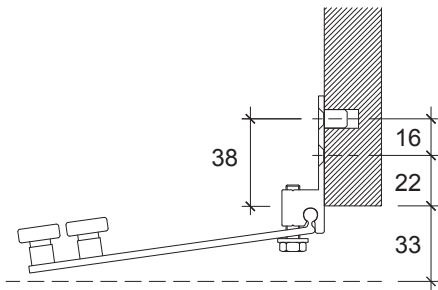

FISSAGGIO STAFFA INFERIORE H33

Lower Alu connecting plate H33

● spine di centraggio / dowel pin
fori ciechi / holes $\varnothing 8.2$ prof. / depth 15mm

⊙ viti di fissaggio / screws

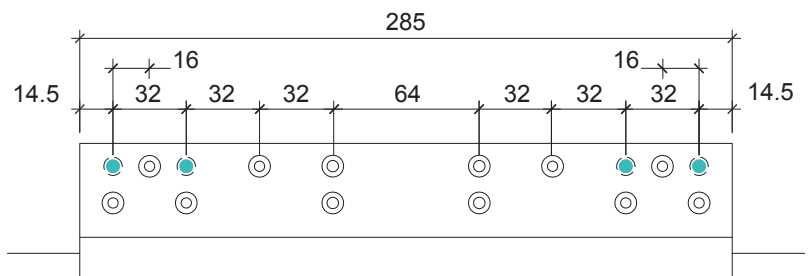
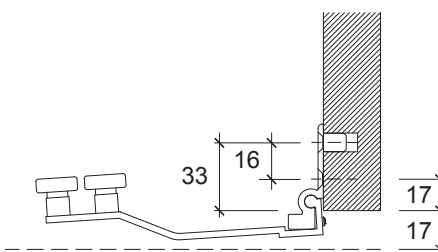

FISSAGGIO STAFFA INFERIORE H17

Lower Alu connecting plate H17

● spine di centraggio / dowel pin
fori ciechi / holes $\varnothing 8.2$ prof. / depth 15mm

⊙ viti di fissaggio / screws



BINARIO INFERIORE
Bottom rail

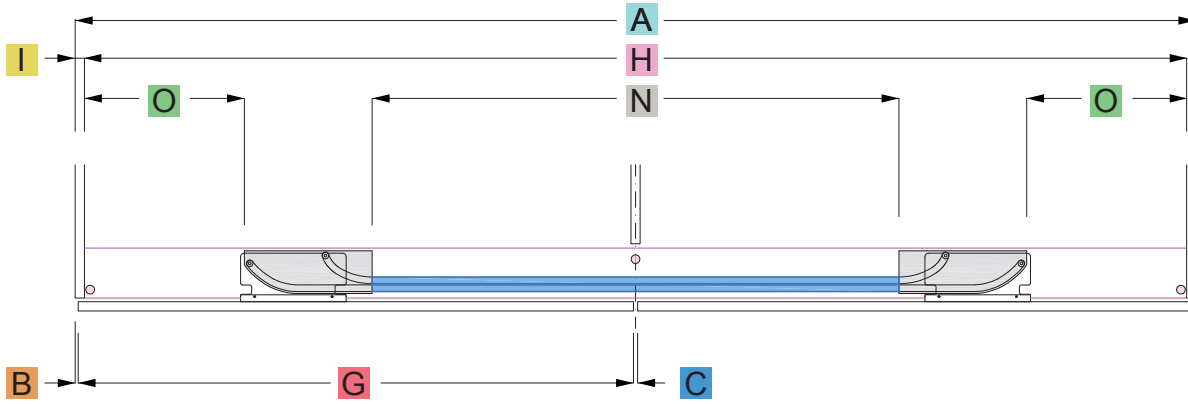

BINARIO SUPERIORE
Top rail

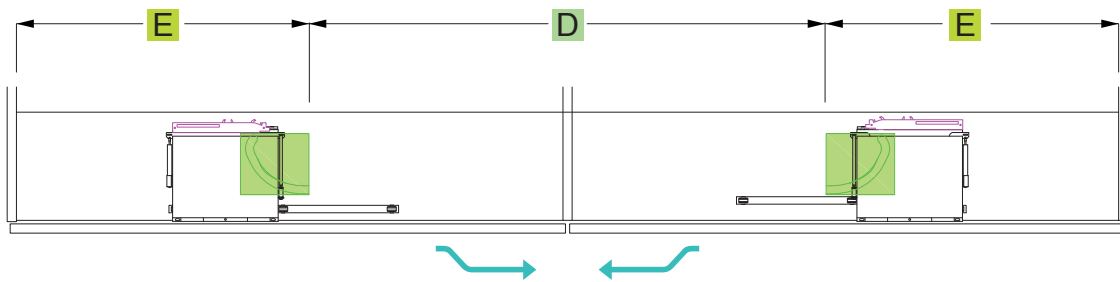

ANTE
Doors

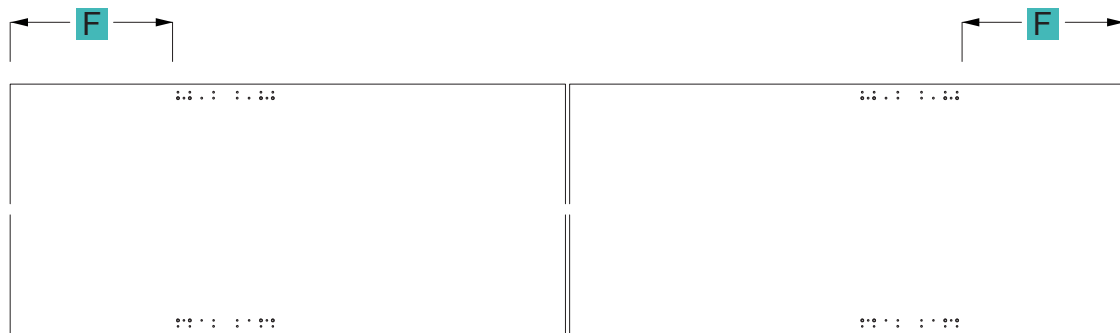

A = larghezza totale / total width

C = distanza ante / doors range

D = distanza curve superiori / upper curves range

D = **G** - 127 mm

G = larghezza ante / door width

N = **D** + 35 mm

G = $\frac{A - (2B + C)}{2}$

H = lunghezza binario / rail length

H = **A** - (2 **I**) - 2 mm

E = $\frac{H - D}{2}$

O = $\frac{H - (N + 690 \text{ mm})}{2}$

F = (**E** + **I** + 1) - (**B** + 353,5 mm)



BINARIO INFERIORE Bottom rail

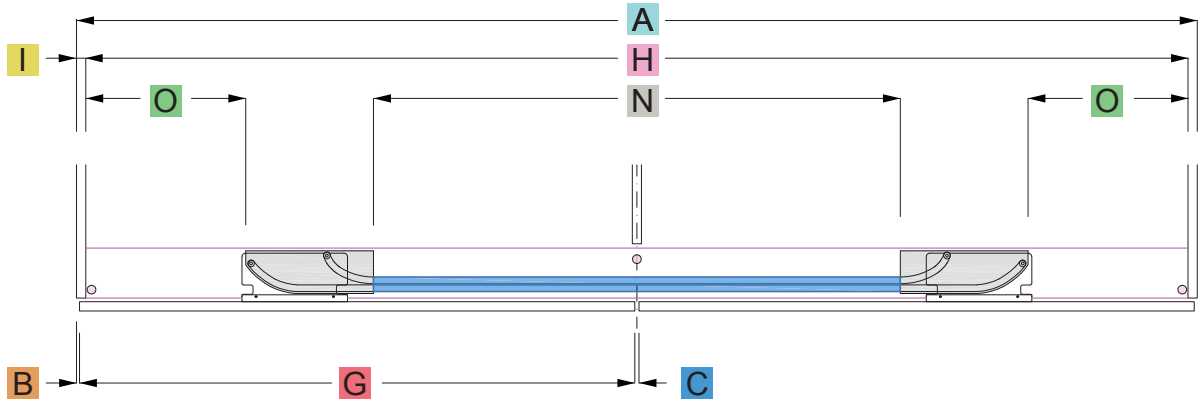

BINARIO SUPERIORE Top rail

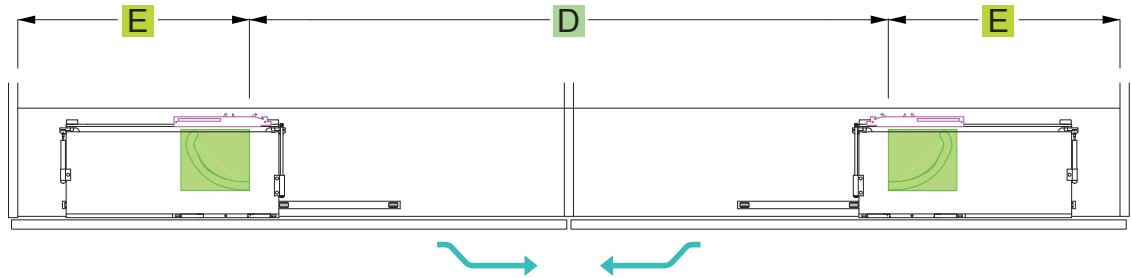

ANTE Doors

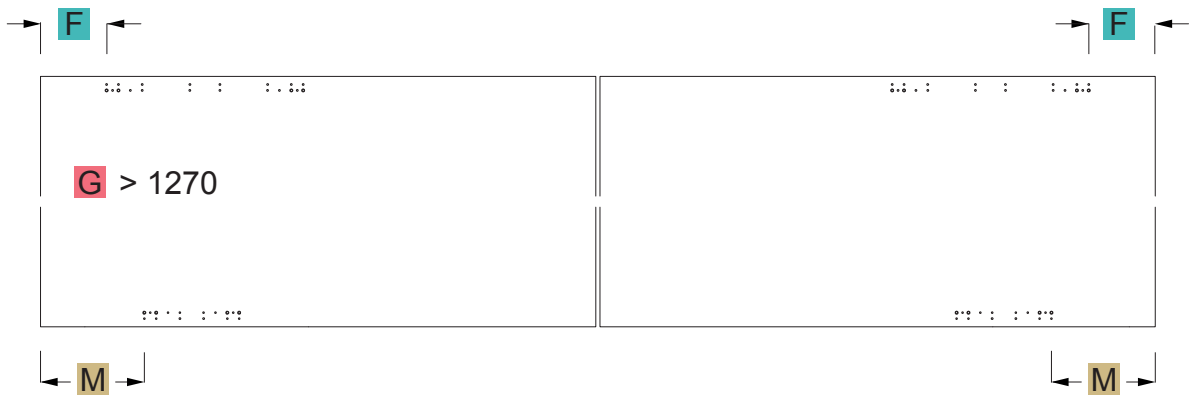

A = larghezza totale / total width

C = distanza ante / doors range

D = distanza curve superiori / upper curves range

D = **G** + 193 mm

G = larghezza ante / door width

N = **D** + 35 mm

F = $(\mathbf{E} + \mathbf{I} + 1) - (\mathbf{B} + 481,5 \text{ mm})$

M = $(\mathbf{E} + \mathbf{I} + 1) - (\mathbf{B} + 353,5 \text{ mm})$

$$\mathbf{G} = \frac{\mathbf{A} - (2\mathbf{B} + \mathbf{C})}{2}$$

H = lunghezza binario / rail length

$$\mathbf{H} = \mathbf{A} - (2\mathbf{I}) - 2 \text{ mm}$$

$$\mathbf{E} = \frac{\mathbf{H} - \mathbf{D}}{2}$$

$$\mathbf{O} = \frac{\mathbf{H} - (\mathbf{N} + 690 \text{ mm})}{2}$$



BINARIO INFERIORE
Bottom rail

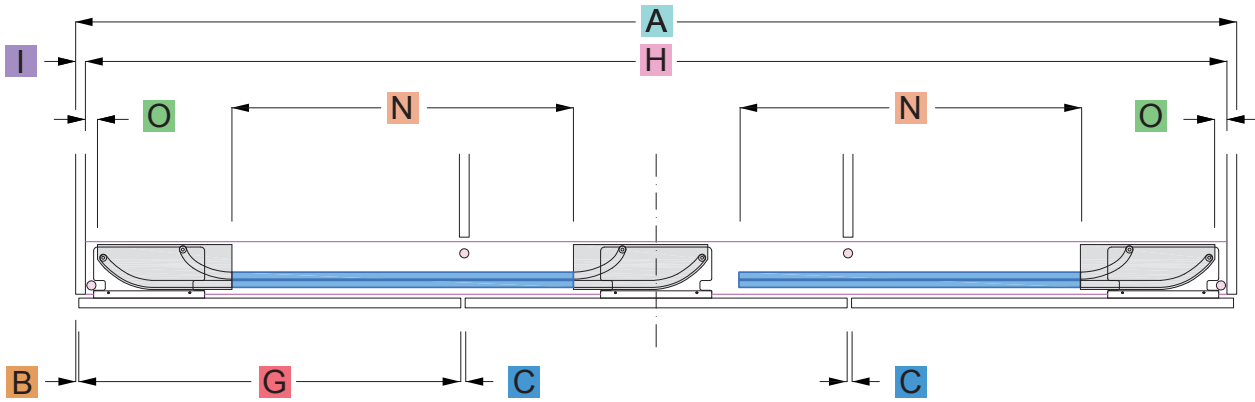

BINARIO SUPERIORE
Top rail

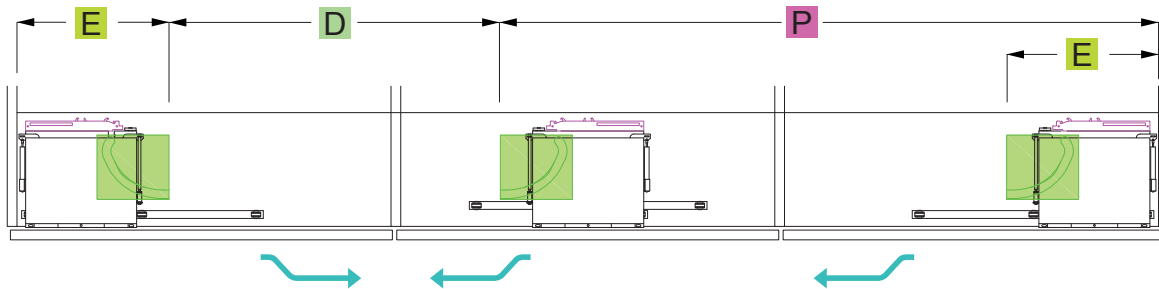

ANTE
Doors

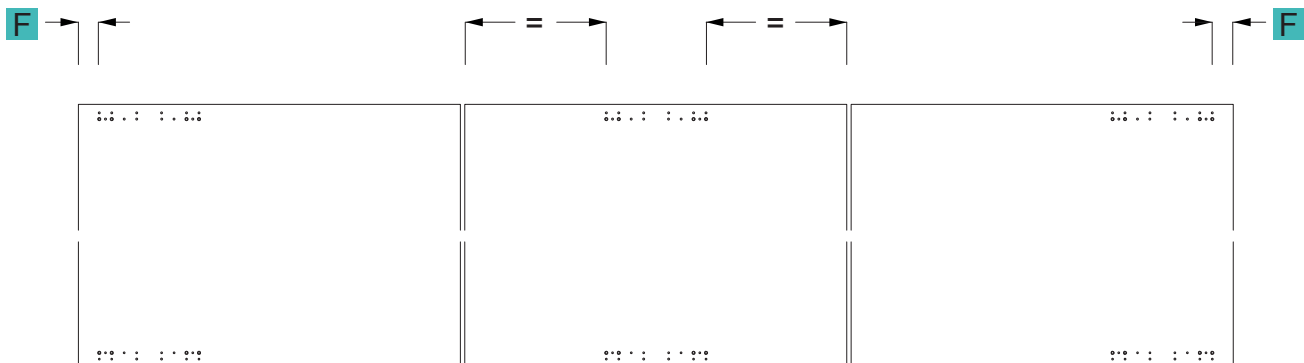

A = larghezza totale / total width

C = distanza ante / doors range

H = lunghezza binario / rail length

H = $A - (2 \cdot I) - 2 \text{ mm}$

D = distanza curve superiori / upper curves range

D = $H - (P + 389 \text{ mm})$

E = 389 mm

O = 26,5 mm

$$P = \frac{H}{2} + 225,5 \text{ mm}$$

$$N = D + 35 \text{ mm}$$

G = larghezza ante / door width

$$G = \frac{A - (2 \cdot B + 2 \cdot C)}{3}$$

$$F = (I + 390) - (B + 353,5 \text{ mm})$$

APERTURA ORECCHIE
CARRELLO
doors fixing system opening

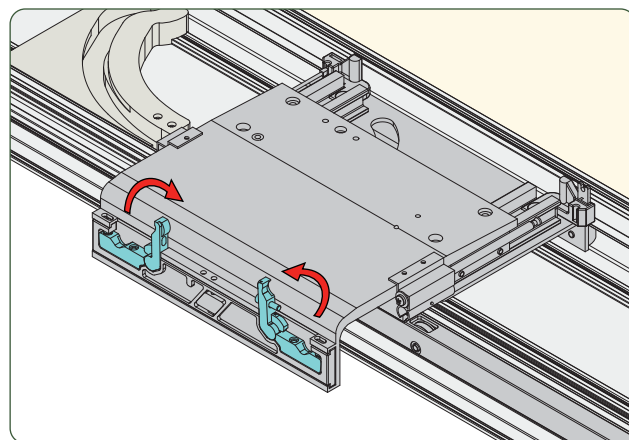

AGGANCO E FISSAGGIO ANTA
door mounting and locking

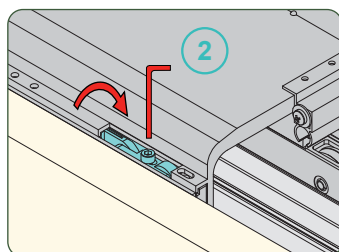
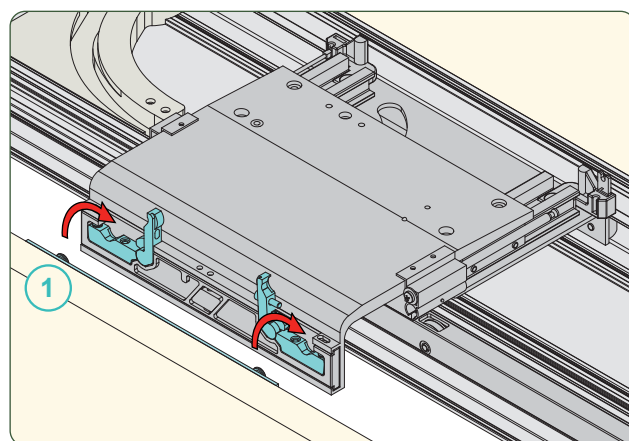

REGOLAZIONE VERTICALE ANTA
vertical setting

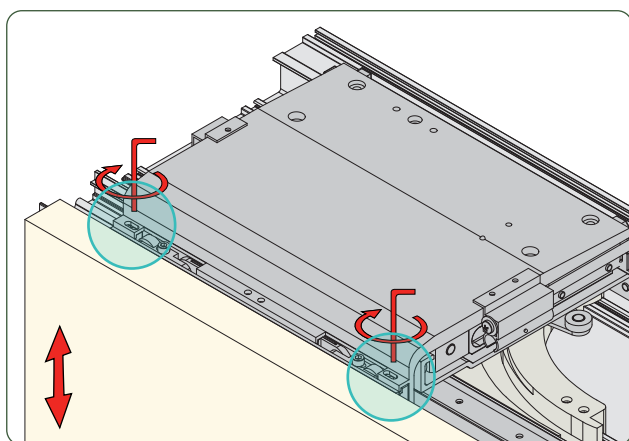

! *il pattino inferiore
deve essere aperto
the lower track
must be open*

! *le ante devono essere chiuse
the doors must be close*

REGOLAZIONE DX / SX
left / right setting

1 vite di regolazione DX e SX
right and left setting screw

! *il pattino inferiore
deve essere aperto
the lower track
must be open*

! *le ante devono essere chiuse
the doors must be close*

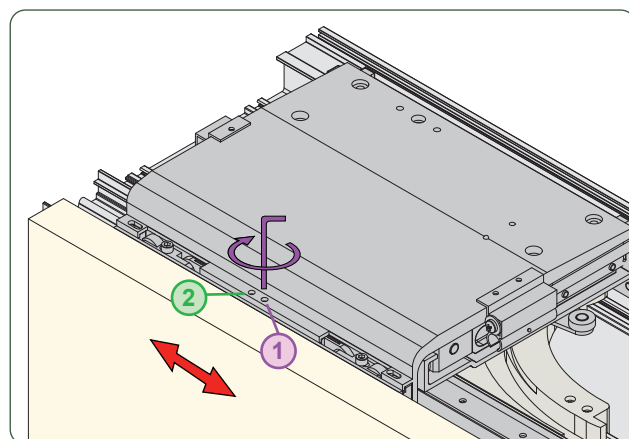

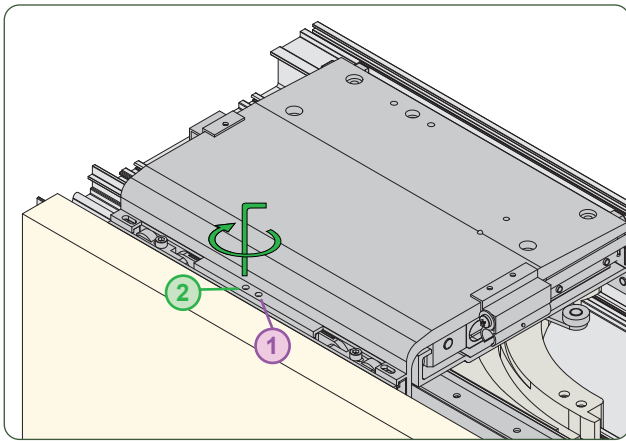

BLOCCAGGIO REGOLAZIONI

locking adjustment

- ② vite di bloccaggio
locking screw

! *effettuare il bloccaggio dopo aver regolato l'anta*
lock after the door setting

INSERIMENTO PATTINO INFERIORE

lower truck insertion

! *le ante devono essere chiuse*
the doors must be close

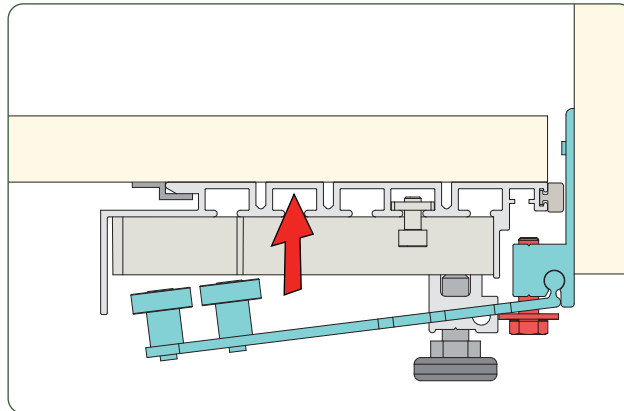

REGOLAZIONE E FISSAGGIO PATTINO INFERIORE

lower truck setting and locking

! *le ante devono essere chiuse*
the doors must be close

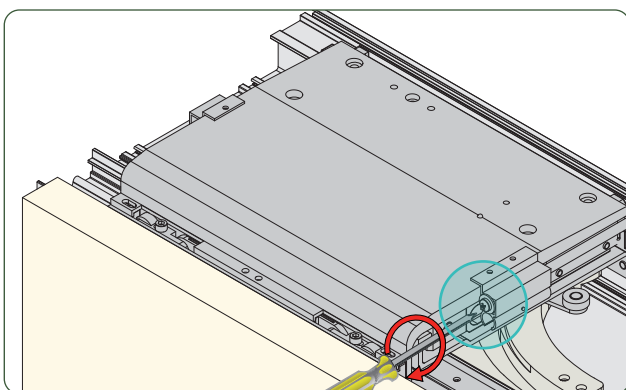
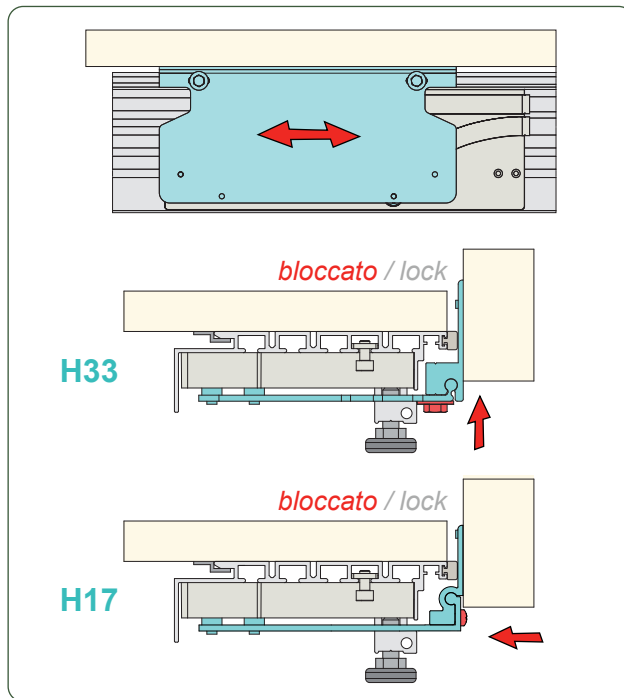

REGOLAZIONE TENSIONE ANTA

door tension adjustment





POSIZIONAMENTO TUBO RUOTE SU CARRELLO SUPERIORE CX / DX

wheels tube placement on central/right upper truck

! *Disegno meccanismo con tubo portaruote rivolto verso l'alto*
Mechanism drawing with wheels tube facing up

POSIZIONE 1 fori A
position 1 / holes A

online3

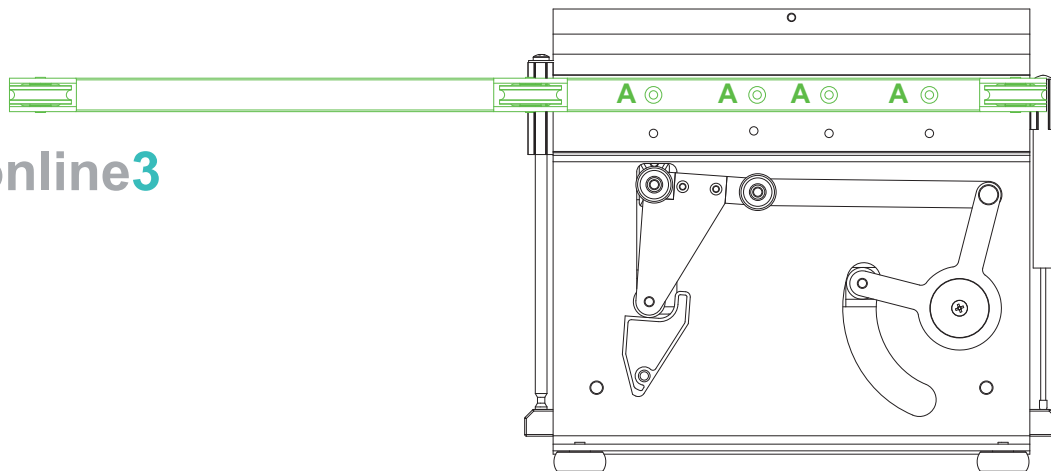

POSIZIONE 2 fori B
position 2 / holes B

online2

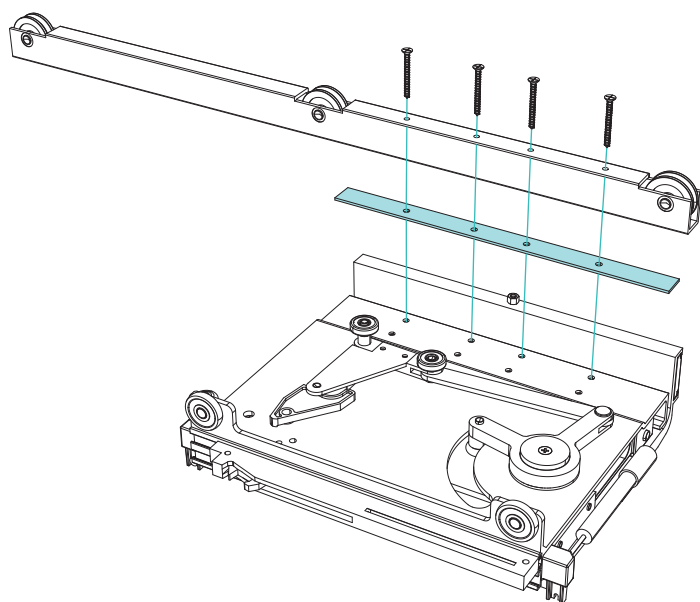
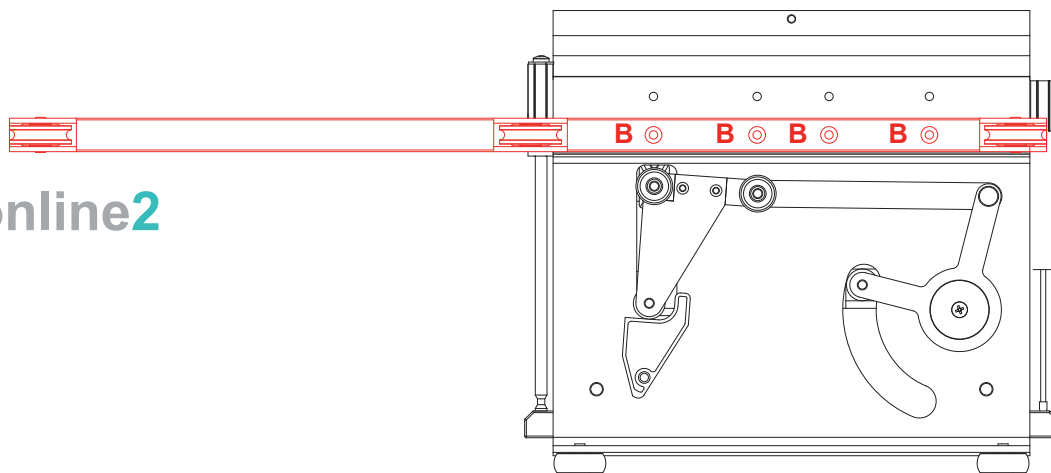

MONTAGGIO TUBO PORTARUOTE
wheels tube mounting

! *inserire la piastra tra il meccanismo
ed il tubo portaruote*
*insert the plate between the
mechanism and the wheels tube*

Brevetto n. MI2010A001444

Mixal si avvale della facoltà di apportare modifiche
tecniche e strutturali ai prodotti senza preavviso.
Project partner: Angelo Molteni & Decoma Design

CONFIGURAZIONE ARMADIO 3 ANTE CON CARRELLI STANDARD

3 doors configuration with standard trucks

SX / left

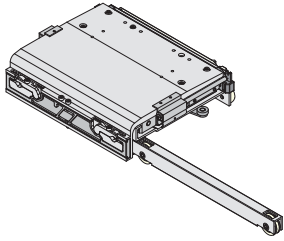

meccanismo SX
tubo portaruote
predisposto in
posizione A
left mechanism
wheels tube ready in
position A

CX / center

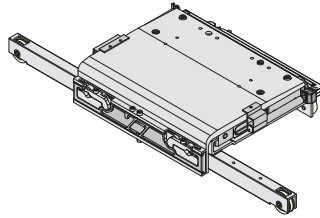

meccanismo CX
tubo portaruote **da**
montare in
posizione B
central mechanism
wheels tube ready in
position B

DX / right

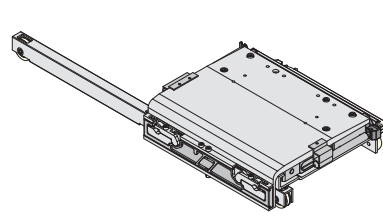

meccanismo DX
tubo portaruote **da**
spostare in
posizione A
right mechanism
wheels tube to move in
position A

CONFIGURAZIONE ARMADIO 2 ANTE CON CARRELLI STANDARD

2 doors configuration with standard trucks

SX / left

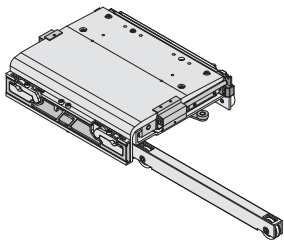

meccanismo SX
tubo portaruote
predisposto in
posizione A
left mechanism
wheels tube ready in
position A

DX / right

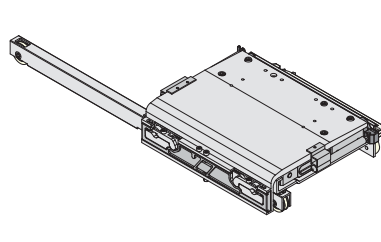

meccanismo DX
tubo portaruote
predisposto in
posizione B
right mechanism
wheels tube ready in
position B

CONFIGURAZIONE ARMADIO 2 ANTE CON CARRELLI STRONG

2 doors configuration with large trucks

SX / left

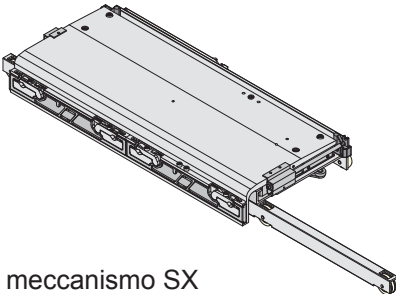

meccanismo SX
tubo portaruote
predisposto in
posizione A
left mechanism
wheels tube ready in
position A

DX / right

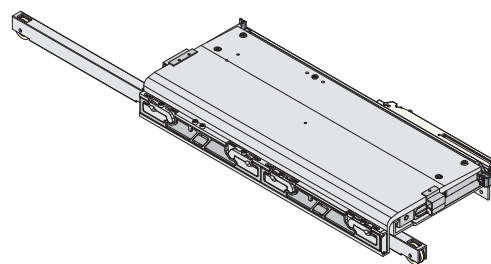

meccanismo DX
tubo portaruote
predisposto in
posizione B
right mechanism
wheels tube ready in
position B





Mixal, società che offre il proprio know-how specifico nella lavorazione dell'alluminio e la propria collaborazione per sviluppare il prodotto più idoneo alle idee del mercato ed ai progetti di ogni azienda. Da sempre attenta alle specifiche esigenze nelle finiture ed ai dettagli tecnico/estetico di ogni particolare.

Mixal, offerig it's specific know-how in the aluminium processing and total co-operation in developing a product which complies with any market requirements and company projects. It's always careful to specific needs and technical/aesthetic features in each details.

MIXAL

MIXAL

22040 Anzano del Parco (CO), via per Cavolto 4 / A
telefono +39.031.6878050 - fax +39.031.6878069
www.mixal.it - commerciale@mixal.it - tecnico@mixal.it

UNITÀ PRODUTTIVA 2

31050 Olmi S.Biagio di Callalta (TV), via E.Fermi, 2
telefono +39.0422.892719 - fax + 39.0422.892727